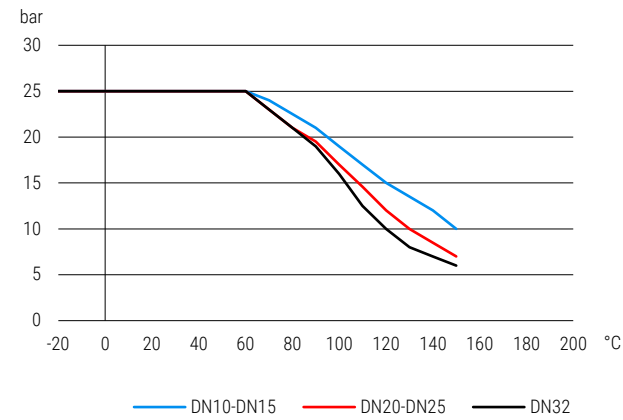

**920.3 | Messing | Flügelgriff | IG/AG | PN25 | Nur in VPE**
920.3 | Brass | T-handle | F/M | PN25 | Only in PU

Druck-Temperatur-Diagramm pressure-temperature-diagram

**Konstruktionsmerkmale Kugelhahn**

- Voller Durchgang nach DIN EN 1983
- Gehäuse aus Messing sandgestrahlt vernickelt
- Wartungsfrei
- Stopfbuchsenmutter muss in zeitlichen Abständen nachgezogen werden
- Ausblässichere Schaltwelle
- Schwimmende Kugel
- Gewinde nach DIN ISO 228-1
- Kennzeichnung nach EN 19

Standardtemperaturbereich

- 20°C bis + 150°C (abhängig vom Betriebsdruck)
Siehe Druck-Temperaturdiagramm

Verwendung

Heizungskreisläufe, Wasser allgemein, Druckluft, Tyfocor, Öl, Heizöl, Kraftstoffe

Design features ball valve

- Full port acc. to DIN EN 1983
- Brass body sand blasted and nickel plated
- Maintenance-free
- Gland nut has to be retightened within certain periods
- Blow out proved stem design
- Floating ball
- Thread acc. to DIN ISO 228-1
- Marking acc. to EN 19

Standard temperature range

- 20°C to + 150°C (depending on working pressure)
Take a look at the pressure-temperature-diagram

Suitable for

Heating circuits, general water, Compressed air, Tyfocor, Oils, Heating oil, Fuels



BESTELLBEISPIEL: Kugelhahn Innengewinde/Außengewinde mit Flügelgriff Größe 1/2" = 920.3-1/2" Artikel-Nr. 0020062031015 (Bezug nur in VPE)
ORDERING EXAMPLE: Ball valve female/male thread with T-handle size 1/2" = 920.3-1/2" item number 0020062031015 (Supply only in packaging units)

Datentabelle data table

D1	D2	DN	LW	PN	L	L1	L2	MM	R	H	D	SW	Gewicht Weight (kg)	Artikel-Nr. Item number
		(mm)	(mm)	(bar)	(mm)	(mm)	(mm)	(mm)	(mm)	(mm)	(mm)	(mm)		
G 3/8"	G 3/8"	10	10	25	44	8,5	8,5	23	25	38,2	28	21	0,130	0020062031010
G 1/2"	G 1/2"	15	14	25	47	10	10	24	25	42,3	28	25	0,162	0020062031015
G 3/4"	G 3/4"	20	19	25	53	11	10	27,5	25	45,8	35,7	31	0,192	0020062031020
G 1"	G 1"	25	24	25	65	13	13	33	33	52,2	43,7	37	0,334	0020062031025
G 1 1/4"	G 1 1/4"	32	30	25	74,7	15	13	38,7	33	56,2	52,5	46	0,476	0020062031032

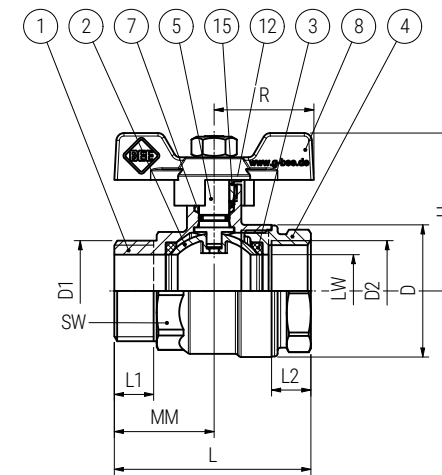
Maßskizze measured sketch**Materialtabelle materials grid**

Nr. No.	Bezeichnung Description	Werkstoff Material	Materialbezeichnung Material description
1	Gehäuse Body	Messing vernickelt Brass (nickel-plated)	CW617N
2	Kugel Ball	Messing verchromt Brass (chrome-plated)	CW617N
3	Kugeldichtung Ball seal	PTFE	-
4	Flansch / Nippel Flange / nipple	Messing vernickelt Brass (nickel-plated)	CW617N
5	Schaltwelle Stem	Messing vernickelt Brass (nickel-plated)	CW617N
7	Spindeldichtung Spindle seal	FKM + PTFE	-
8	Griff Handle	Aluminium	-
12	Packung Packing	PTFE	-
15	Packungsmutter Packing nut	Messing vernickelt Brass (nickel-plated)	CW617N

**Verpackungseinheiten
Packing units**

DN	VPE Packing unit	Umkarton Box
G 3/8"	10	40
G 1/2"	12	48
G 3/4"	12	48
G 1"	9	36
G 1 1/4"	4	16